

LANDQUIP FORKLIFTS

LANDQUIP®



A TRADITION OF EXCELLENCE CONTINUES

After 50 years as the leading name in tractor-mounted forklifts, Hustler Equipment has passed the baton to Landquip, who is now the proud owner of the forklift division.

The two companies are no strangers to each other, having worked closely together for decades. While the name on the side of the forklifts will change, customers can be assured that Landquip will uphold the Hustler tradition of innovation and manufacturing excellence.

"We're happy to see Hustler Forklifts pass into the hands of a company with which we've always enjoyed a close relationship. Having assisted us with R&D and forklift repairs for many years, Landquip knows our products intimately and shares the same values when it comes to equipment design and manufacture."

BRENT CURRIE, HUSTLER EQUIPMENT INC.

LANDQUIP[®]

04 VMX FORKLIFTS



06 TOOL CARRIER FARM



08 TOOL CARRIER VINEYARD



13 LOADFLOATER



14 ECONOMY FORKLIFT



14 MINILIFTS



VMX RANGE

HIGH VISIBILITY FORKLIFTS

MAXIMUM VISIBILITY

With the VMX Forklift, Hustler set out to solve the problems users faced with existing tractor mounted forklifts. VMX stands for 'visibility maximum' – our focus was to give the operator a clearer view of his load for quicker and safer operation.

Our patented clearview forks and open carrier frame lets the operator see directly down the outside of the frame to the fork tips. We mounted the tilt cylinder out of the way vertically in front of the bonnet of the tractor. The rams are tucked away into the mast to allow the driver to see clearly through the centre of the mast.

OSH APPROVED

Hustler worked closely with OSH during development and our VMX masts comply with OSH Hazard assessment requirements.

PRECISION ENGINEERING

The VMX mast design gives precision sliding with no side sway. Durable double sealed roller bearing and case hardened rollers are employed. The outer section features bolted construction instead of welding to eliminate distortion.

Precision high tensile steel i-beams produced in Germany complete this radical design.

All front mounted models come standard with tilt. Sideshift is available as an option on any model. When not in use the forks can fold over out of the way.

Ultimate visibility - patented clearview fork design

Clean, uncluttered design

High tensile 'i-beam' sourced from Germany

9 common models including compact 3 and 2 stage models

Many safety features incorporated

VMX 2/12/1.7m

Ideal for vineyard or orchard use



Power block kit option

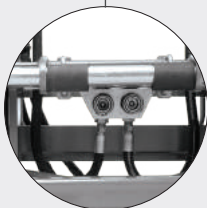

Fold away forks standard



High back frame option

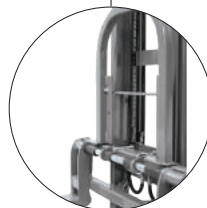

Hydrafloater option



Patented clearview fork and carrier frame

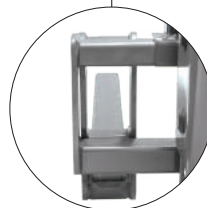

Modular bolted frame



VMX SPECIFICATIONS

MODELS AVAILABLE: 2 + 3 stage

LIFT HEIGHT: 1.1m to 3.6m

LIFT CAPACITY: 1200kg + 1500kg

UNIT WEIGHT: 200kg - 550kg

HYDRAULICS REQUIRED: 12-60 litres/min,
2500-3000psi

APPLICATIONS:

Apples, pears, plums, pineapples, avocados, grapes, kiwifruit, citrus, carrots, potatoes, cabbages, squash, you name it...

**VMX MOUNTING OPTION 1:
FRONT MOUNTING**

Any VMX fork mast can be mounted to the front of a tractor, subject to tractor size. All Hustler front mounted fork masts with the exception of Rolatrac use our innovative modular iMAX system.

THE iMAX™ SYSTEM

The unique iMAX system integrates the mountings, tilting system and sideshift mechanism in one ultra compact unit, virtually hidden by the front of the tractor and giving almost unobstructed vision down the side of the bonnet.

MODULAR SYSTEM

iMAX is an integrated and compact unit that is extremely quick to mount to the front of a tractor

QUICK FITTING

The modular iMAX system affords exceptionally easy fitting and simple adaptability from tractor to tractor. The VMX mast can be disconnected from the tractor in less than two minutes by one person.

**VMX MOUNTING OPTION 2:
3-POINT-LINKAGE MOUNTING**

Three point linkage mounts can be fitted on any VMX fork mast allowing it to be quickly and easily fitted in the same way as any other implement.

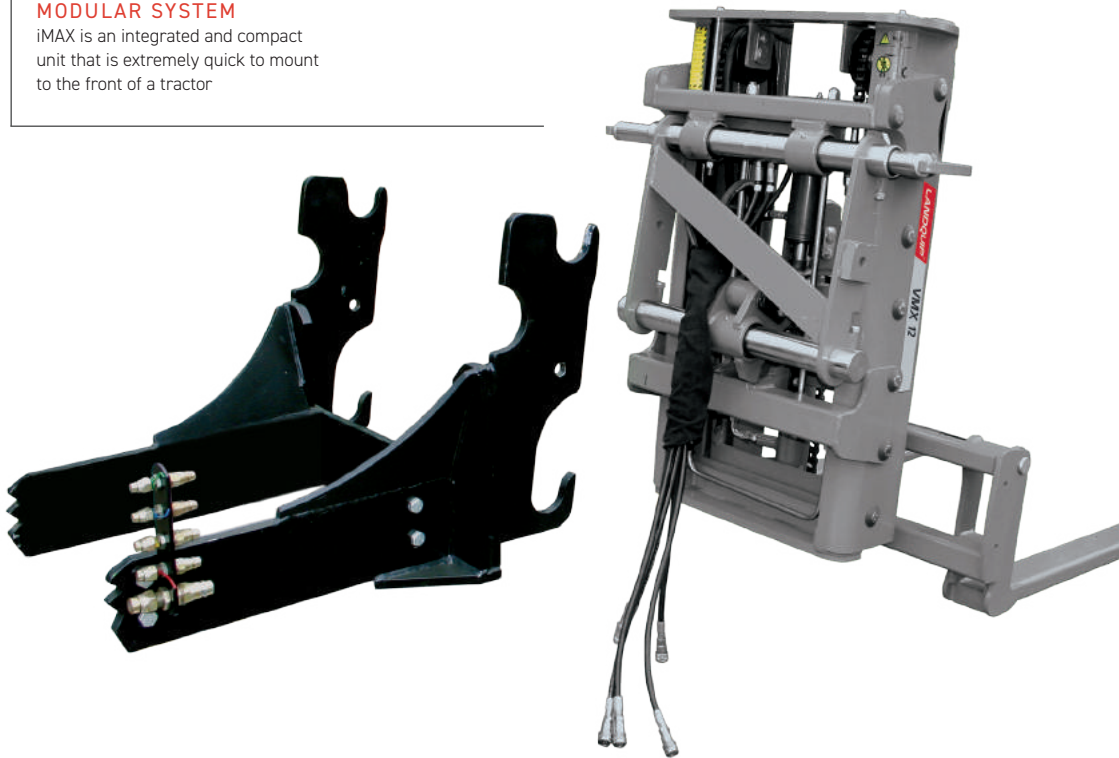

3 point linkage mount



Front mount with tilt only



Front mount with tilt and sideshift

IMAX MOUNTING SEQUENCE

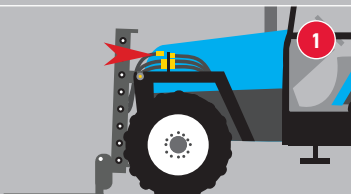

Undo quick release couplings

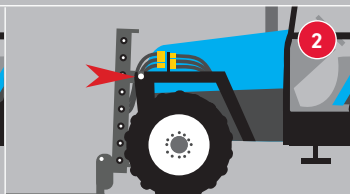

Remove loose fitting pins

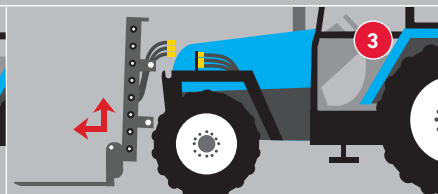

Lift fork unit and back away



Phone +64 6 879 4992
sales@landquip.co.nz
www.landquip.co.nz

VMX RANGE

HIGH VISIBILITY FORKLIFT MODELS



VMX 3/12/1.7m

- **Ideal for orchard use**
- 3 stage design allows a very compact mast height
- Heavy-duty 1.2 tonne lift capacity to 1.7m lift height
- Ideal for moving around and under trees without damaging fruit
- Will lift up to 2 bins to truck deck height
- Freelift standard (600mm freelift travel)



VMX 2/12/2.7m

- **Ideal for grapes, orchard or general purpose**
- Heavy-duty 1.2 tonne lift capacity to 2.7m lift height
- Good for applications where height is not restricted

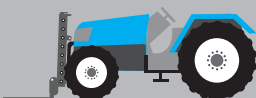

3 stage lowered



3 stage showing freelift (standard on all models)

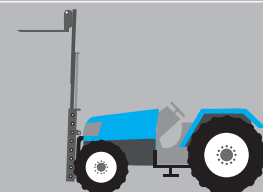

3 stage raised



VMX 2/15/3.0m

- **Ideal for cropping use**
- 2-stage
- Heavy-duty 1.5 tonne lift capacity to 3.0m lift height
- Good for applications where height is not restricted
- High ground clearance (450mm)

MODEL	2/12/1.1m	2/12/1.4m	2/12/1.7m	2/12/2.7m	2/12/3.0m	3/12/1.7m	3/12/2.2m	3/12/2.5m	2/15/3.0m	3/15/2.5m
Stages	2	2	2	2	2	3	3	3	2	3
Capacity	1200kg	1200kg	1200kg	1200kg	1200kg	1200kg	1200kg	1200kg	1500kg	1500kg
Lift height	1120mm	1420mm	1720mm	2700mm	3000mm	1720mm	2220mm	2550mm	3000mm	2550mm
Freelift	None	None	None	None	None	600mm	710mm	820mm	None	820mm
Closed mounted height	1140mm	1280mm	1430mm	1924mm	2170mm	1140mm	1280mm	1390mm	2220mm	1390mm
Ground clearance height	150mm	150mm	150mm	300mm	300mm	150mm	150mm	150mm	450mm	150mm
Optional ground clearance	300mm	300mm	300mm	450mm	450mm	300mm	300mm	300mm	600mm	300mm
Use	orchard	orchard	orchard	general	general	orchard	orchard	orchard	cropping	orchard

Model key: 2 = 2 stage 3 = 3 stage / 12 = 1200kg 15 = 1500kg / 1.1 = 1.1m lift height

OPTIONS: Extra 150mm ground clearance • 1200mm long forks (1070mm standard) • Hydrafloater • We offer 20 other sizes, other than what's featured on this chart.

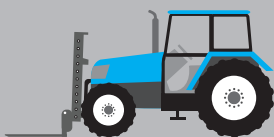

2 stage lowered

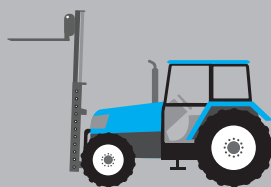

2 stage raised



Phone +64 6 879 4992
 sales@landquip.co.nz
 www.landquip.co.nz

VMX TOOLCARRIER FARM

TOOL MOUNTING SYSTEM

- Up to 1500kg lifting capacity
- Up to 3.0m lift height
- Hustler clearview design mast
- Optional hydraulic toplinek
- Can be adapted to fit the front of the tractor
- Accepts Eurohitch implements
- Around half the cost of a front end loader

Handling Solution

A new handling situation has arisen for farmers as more and more bulk goods arrive to the farm on pallets.

VMX Toolcarrier Farm is an innovative and versatile new concept which gives farmers a convenient, cost effective alternative to a front-end loader. It is excellent as a secondary lifting unit on the farm.

VMX Toolcarrier can be quickly and easily fitted to any tractor on your farm via its 3 point linkage and has several important advantages when handling these types of goods.

VMX TOOLCARRIERS ADVANTAGES

- **The weight is carried over the rear wheels giving increased stability, safety and manoeuvrability**
- **The mast lifts straight up and down to a height of up to 3 metres, not in an arc like a front loader, again keeping the weight close to the rear wheels**
- **Excellent stability over rough ground**
- **Fitting a VMX Toolcarrier on a reserve tractor is a very cost effective option**

EUROHITCH CONVENIENCE

VMX Toolcarrier Farm incorporates the industry standard Eurohitch fitment, allowing any Eurohitch attachments to be fitted.

Bale grabs, bale forks, pallet forks, in fact almost anything you would normally attach to your 3 point linkage, can be fitted.* And with VMX Toolcarrier fitted you can still hitch a trailer to your drawbar.

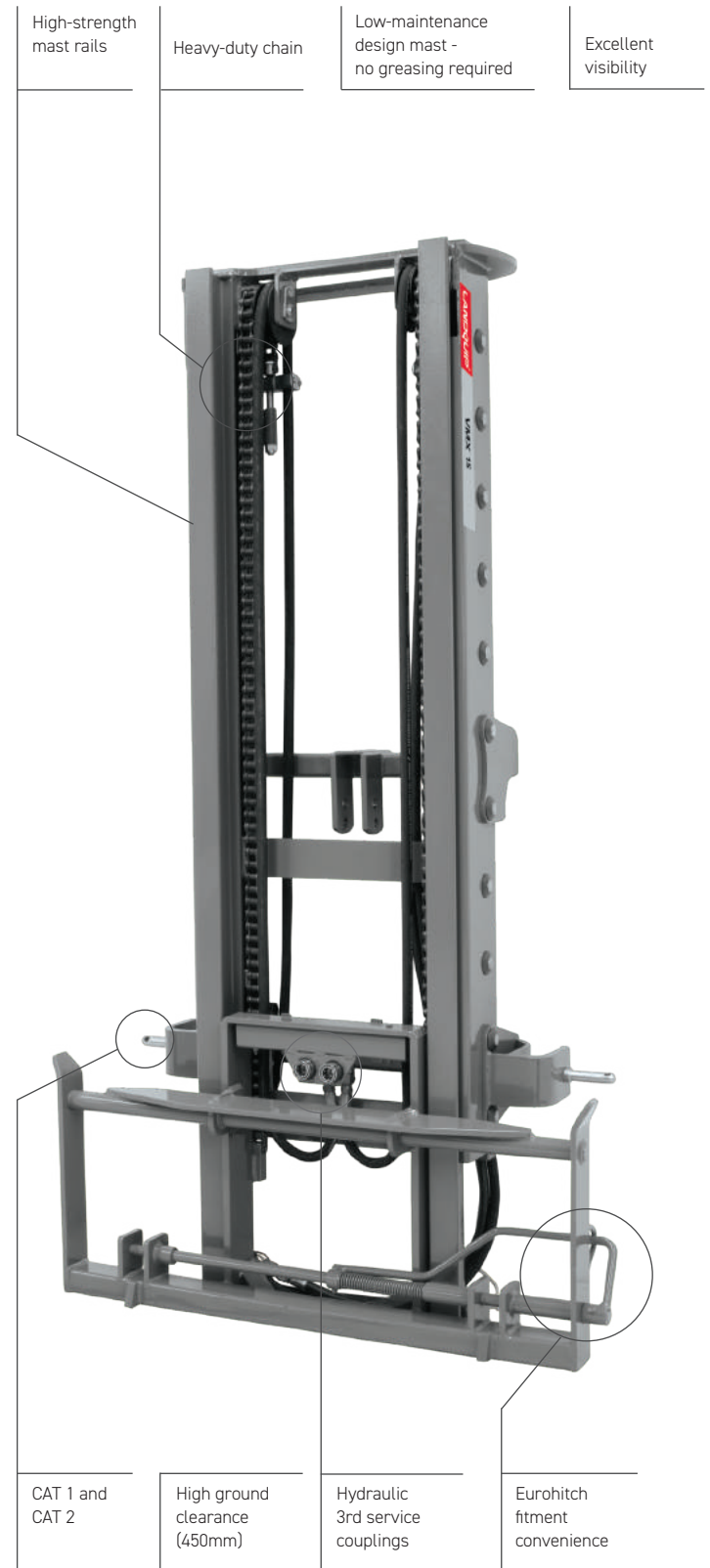

VMX TOOLCARRIER FARM SPECIFICATIONS

LIFTING CAPACITY: 1500kg
LIFT HEIGHT: up to 3.0m
UNIT WEIGHT: 240kg
HYDRAULICS REQUIRED: 1 X single-acting 12-60 litres/min, 2250-3000 psi • double-acting for tilt • double-acting for 3rd service

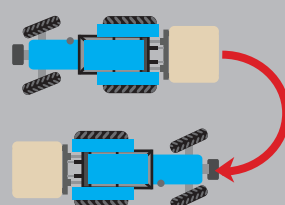

MANOEUVRABLE

Approximately twice as manoeuvrable as a front-end loader

STABLE

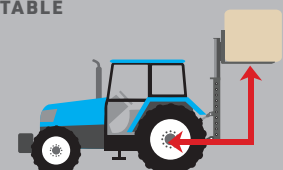

More stable than front-end loader



Big bale handling



Lifting through the loops



1300kg pallet load



“The main reason we have a toolcarrier is to feed out to calves with a gravity feed tank on the forks. The other main reason is to handle pallets of calf meal, milk powder, cosmag and other animal health products. The delivery guys love it, as it is so quick to off-load and they can go.”

DAIRY FARMER, TARANAKI: VMX TOOLCARRIER 2/12/2.7

VERTICAL LIFT

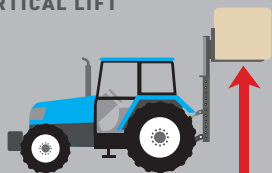

Lifts vertically not in arc, also self-levelling

LIFT CAPACITY

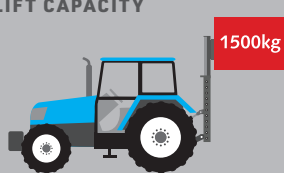

Lifts up to 1.5t (depending on tractor size)

QUICK ATTACH

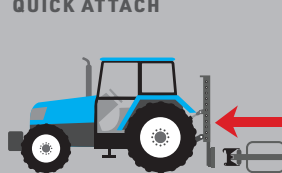

Attach implements quickly with Eurohitch



Phone +64 6 879 4992
sales@landquip.co.nz
www.landquip.co.nz

VMX TOOLCARRIER VINEYARD

TOOL MOUNTING SYSTEM

- High strength mast
- Hustler patented clear view design
- 2 minute removal/fitting to tractor
- Low-maintenance - no greasing required
- 2 popular height options: 1.7m (shown) and 2.7m
- Anti hose burst valve for extra safety
- Refer to page 29 for more VMX mast features
- 1200kg lift capacity

VMX Toolcarrier Vineyard

Hustler's versatile Toolcarrier can quickly mount virtually any implement used on a vineyard: post-hole borers, leaf pluckers, net winders – the list goes on.

Toolcarrier makes it safe and easy for one person to attach implements. No more hammers, spanners, crowbars or frustration and no more vine trimmers dangerously swinging from a block and tackle in the shed.

ULTRA QUICK ATTACHMENT

Simply drive in to the implement sitting on the ground and attach the hydraulic hoses to the 3rd service if required.

You've got hydraulic height adjustment on the move, and the added advantage of a handy set of forks for general lifting around the vineyard.

- High strength mast rails
- Heavy-duty chain
- Low-maintenance design mast - no greasing required
- Excellent visibility



VMX TOOLCARRIER VINEYARD SPECIFICATIONS

- UNIT WEIGHT APPROX: 220kg
- TRACTOR REQUIRED: 60-110 hp, depending on tractor specification
- HYDRAULICS REQUIRED: 1 X single-acting 12-60 litres/min, 2500-3000 psi · double-acting for tilt · double-acting for 3rd service

1

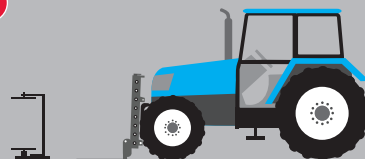

Loading is very simple - drive in to implement

2

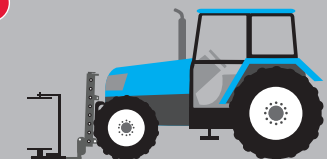

Pick up implement using forks



Spray rig

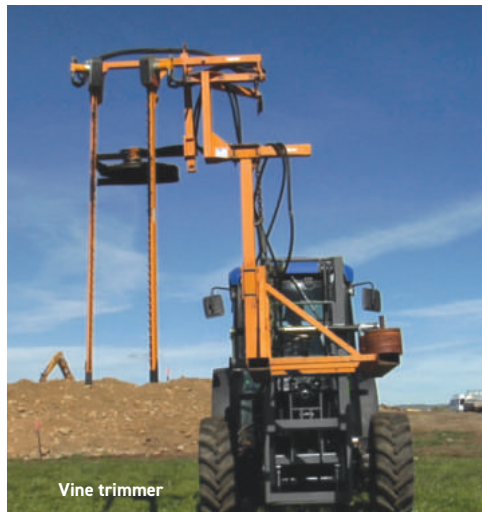

Vine trimmer



Net wrapper



3

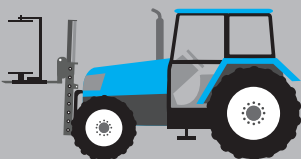

Attach hydraulics if required and ready to work



Phone +64 6 879 4992
sales@landquip.co.nz
www.landquip.co.nz

HYDRAULIC CONTROLS

JOYSTICK, VALVES, OR EXISTING SYSTEM

Joystick controls

A joystick is the ultimate control system for operating a forklift. Due to law disallowing high pressure hydraulic hoses to be inside the cab of tractors, the only options are a cable control joystick or the tractors existing controls. The Joystick controls cables which connect to a 2-bank valve mounted outside the cab. If the forklift has Sideshift, we offer an electric 3rd service button joystick which controls a diverter valve to switch between tilt and Sideshift functions. Landquip uses only top-quality joystick brand BADESTNOST manufactured in Bulgaria.



2 or 3 bank valve controls

Landquip use world leading brand BADESTNOST hydraulic valves manufactured in Bulgaria. This option can only be used on tractors without a cab. Controls are mounted ergonomically and out of the way of branches etc. 3-bank valves are used when the forklift has Sideshift, 2-bank valves are for tilt only options.



Existing Tractor controls

If possible, this option is the most cost effective. However, they are not always very user-friendly. Landquip are happy to utilize any existing hydraulic control system a tractor may have.





LANDQUIP®

Phone +64 6 879 4992
sales@landquip.co.nz
www.landquip.co.nz

LOADFLOATER

PRODUCE HANDLING SYSTEM

A smoother, softer ride for your produce

3 models available: LF1250, LF700, LF700N

100mm X 50mm high strength forks

LF700N: 100mm X 35mm slimline forks

Optimum Fruit Protection

Hustler Loadfloater is a 3 point linkage mounted fork system designed to protect produce from damage.

The hollow urethane suspension system floats the bin while 6 hardened steel rollers provide 200mm of free movement.

Loadfloater works just as well with a partially loaded bin as a full one and allows faster speeds without bruising.

The end result can be a dramatic saving every season. Loadfloaters are particularly useful in market garden situations as produce frequently has to be transported across uneven ground.

“We can travel twice as fast using LF700 compared to conventional forks, with significantly less fruit bruising.

With unsupervised drivers LF700 is a lot more tolerant on fruit.”

ORCHARD MANAGER, HAWKE'S BAY



Loadfloater 1250 2 bin capacity unit (1250kg max)



Loadfloater 700 Popular single orchard unit



Loadfloater 700N Orchard use, carrying single bins end on

LOADFLOATER SPECIFICATIONS

LIFTING CAPACITY: LF1250: up to 1250kg

LF700/LF700N: up to 700kg

UNIT WEIGHT: LF1250: 120kg

LF700/LF700N: 90kg

Minilifts

3PTL MOUNTED LIFT

Economy Forklift

E2/2.1

3 models available: 700kg, 1500kg, 700kg narrow	600kg lifting capacity
M07 Narrow designed for plastic grape bins	2.1 metres lift height
100mm X 50mm profile forks	Low-maintenance, no greasing required
M15: CAT 1 and CAT 2 linkage options	All roller design mast, including roller chain
M07 and M07N: CAT 1 linkage only	CAT 1, 3-point-linkage mounts

Utility Lift

Hustler Minilifts are basic 3-point-linkage mounted lifts, ideal for pallets, bales, troughs and general lifting around the property.



Minilift 15 Market gardening, general farm lifting



Minilift 07 Lighter applications, orchards and small holdings



Minilift 07N Designed for vineyard plastic grape bins



Ideal for beekeepers, small farm holdings, nurseries and lifestylers the E2/2.1 is a good value, all roller mast.

MINILIFT SPECIFICATIONS

E2/2.1 SPECIFICATIONS

LIFTING CAPACITY: M15: up to 1500kg
 M07/M07N: up to 700kg
 UNIT WEIGHT: M15: 60kg
 M07/M07N: 30kg

UNIT WEIGHT APPROX: 160kg
 HYDRAULICS REQUIRED: 1 X single-acting remote, 12-60 litres/min, 2250-3000 psi
 OPTIONAL EXTRAS:
 • Hydraulic toplinek (requires double-acting hydraulics)



Phone +64 6 879 4992
 sales@landquip.co.nz
 www.landquip.co.nz

CONTACT

Landquip Ltd
Box 2299, Stortford Lodge,
359 Wilson Road, Hastings 4153
New Zealand

Phone +64 6 879 4992

sales@landquip.co.nz

www.landquip.co.nz

